

SY 220 / SY 225 / SY 250 Series Underwater lights INSTALLATION OF A LIGHT MODULE TO THE WELD-IN FLANGE

Please read ALL the following pages before attempting installation to ensure complete understanding of what is required

CARE POINTS

This document describes the recommended method for installing the light module of Lumishore SY 220 / SY 225 / SY 250 series lights in order to provide a water tight seal between the flange (previously welded in) and the light.



CAUTION



- DO NOT use any adhesives, sealants, gaskets, cleaning agents or chemicals other than those specified in this manual. Using any materials in the installation that are not specified in this manual will invalidate the warranty
- The light module is a factory sealed unit. DO NOT attempt to take the light apart or remove any bolts from the light
- The flange / light installation must be pressure checked to ensure it has been installed correctly. Ensure this check is carried out as specified
- DO NOT test or switch the lights on if they are covered. This risks damaging the light and lens and will void the warranty.
- DO NOT pressure wash the light, flange or lens under any circumstances. Pressure washing can disturb the sealing arrangement.

Parts Supplied

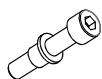

Light Securing Bolt
with Washer and
Insulating Washer
(x7)

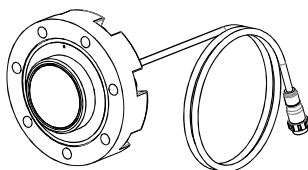

SY 220 / SY 225
/ SY 250 100
Degree Light
and Cable

(OR)

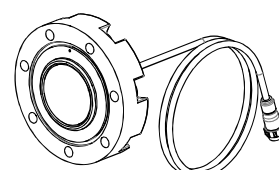

SY 220 / SY 250
60 Degree
Light and
Cable

LIGHT MODULE INSTALLATION

- 1) Check that the lens has been fitted and tested following the procedure 45-0075. Remove the flange cover plate.
- 2) Clean the weld-in flange thoroughly with IPA, and a CLEAN rag. Check the flange for any damage, debris or weld splatter. The gasket mating surfaces must be clean and flat before the light can be fitted.
- 3) There are two different light beam angles for each of the SY 220, and SY 250. These are 60 Degree, and 100 Degree (SY 225). The 100 Degree light has a flat glass front covering the array, and the 60 Degree light has a convex lens covering the array. CHECK THE BEAM ANGLE IS THE CORRECT ANGLE FOR THE HULL POSITION before fitting.
- 4) Check the O ring is in place on the light module. Place the light module over the light and align the holes.

NOTE : SY225 LIGHT MODULE DIFFERS SLIGHTLY FROM DIAGRAM BELOW; HOWEVER, INSTALLATION & TESTING PROEDURES ARE THE SAME

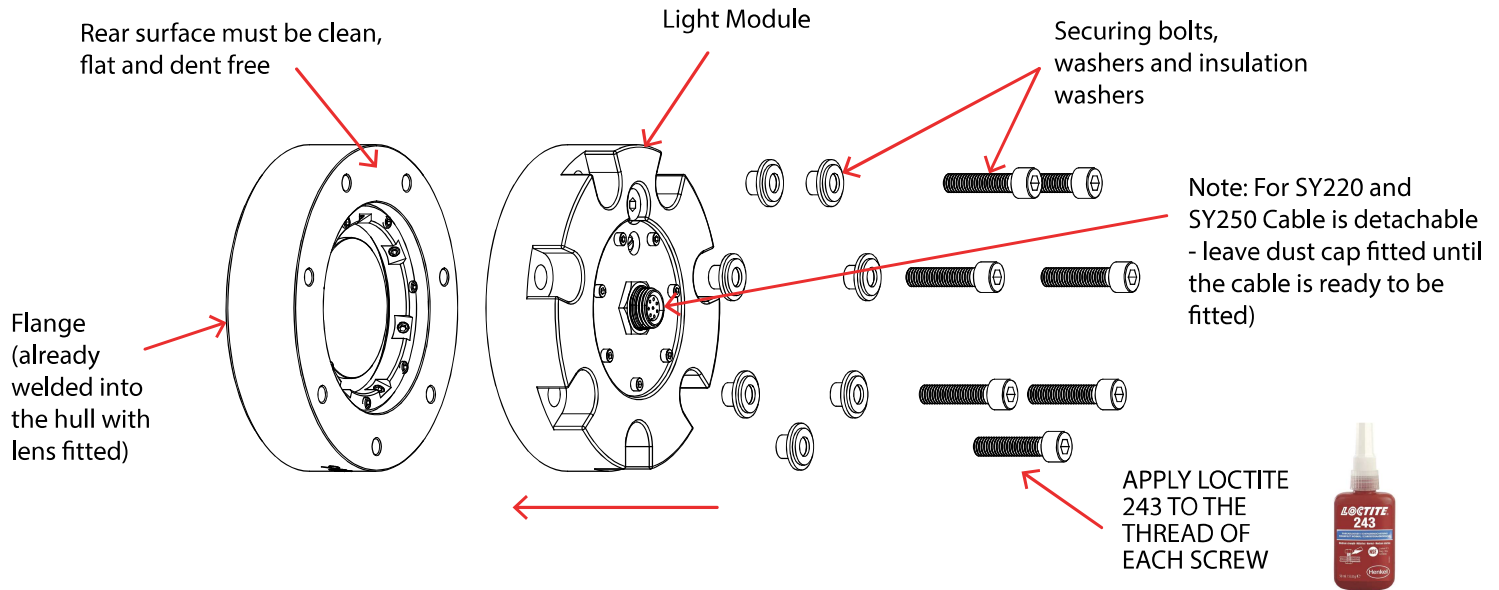

- 5) Apply a small amount of Loctite 243 (supplied) to the thread of each bolt before fitting. Fit the light module to the flange, and secure in place using the bolts - MAKE SURE that the bolts have the washer and nylon insulating washers fitted.

NOTE : THE SY225 REQUIRES FOR THE TOP DEAD CENTER (TDC) TO MATCH THAT OF THE FLANGE.

A SCORE MARK ON THE FLANGE COUPLED WITH "THIS WAY UP" ON THE LIGHT LABEL WILL AID IN IDENTIFYING THE CORRECT ORIENTATION. EXAMPLE AS BELOW...

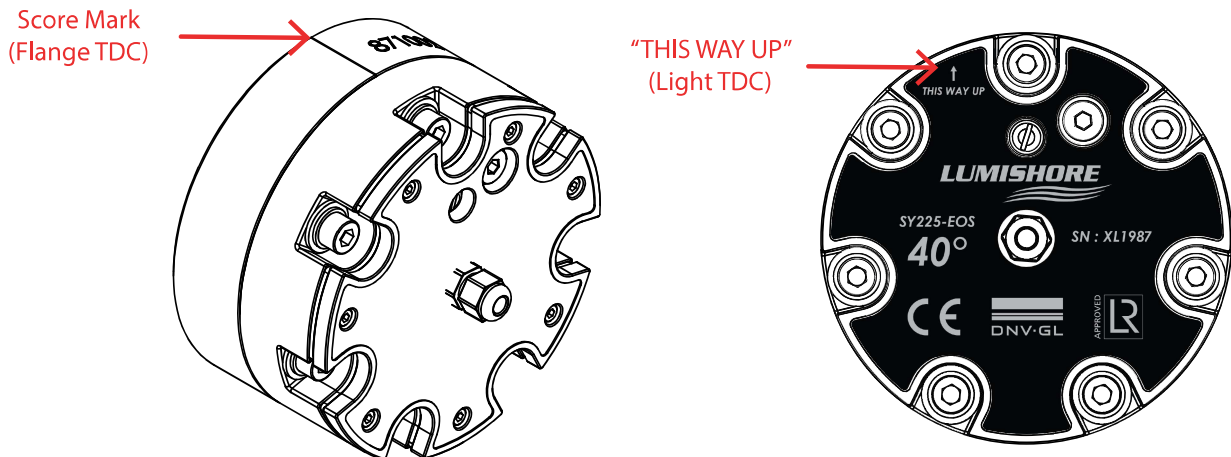

6) Tighten the bolts in a criss-cross pattern (as shown in the diagram). Tighten the bolts half a turn at a time, then move on to the next bolt. USING A TORQUE WRENCH tighten the bolts to a torque of 15 Nm.

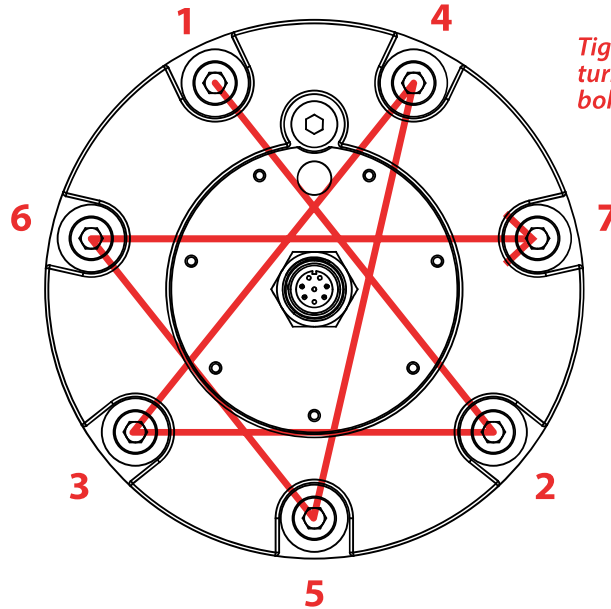

Tighten each bolt half a turn at a time until ALL bolts are fully torqued

7) **FOR ICE CLASS VESSELS** ; Remove patch vent and fit vent screw and dowty seal (found in fitting kit - 39-0052)

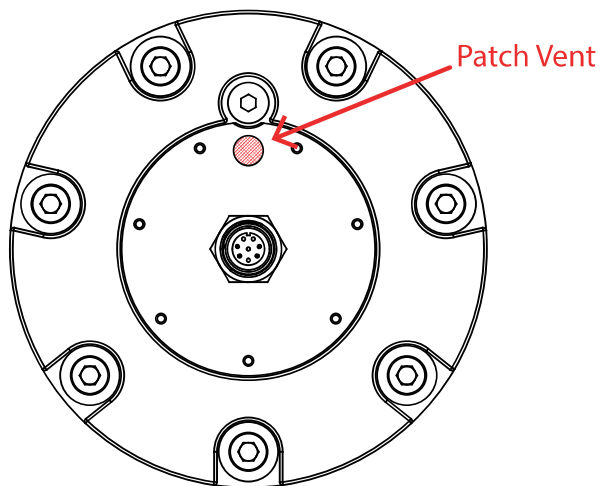

8) Ensure there is no debris or water in either connector. Fit the cable to the back of the light (SY220 and SY250). Ensure that the key on the cable connector, and the key on the light connector line up. Screw the connector home. The connector should fit easily - DO NOT force the connector.

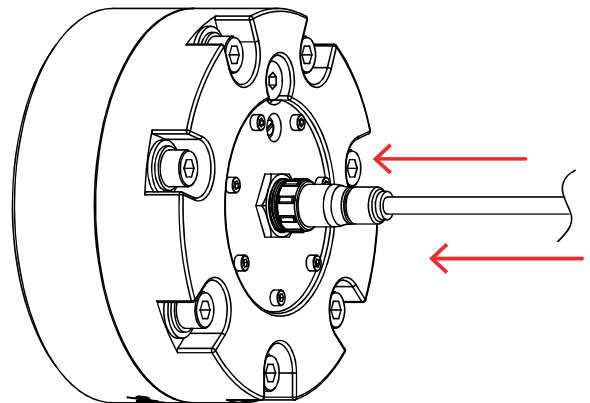

NOTE: The cable can be fitted at any time. If the cable is not fitted at this stage ensure that the DUST CAP IS IN PLACE on the back of the light.

PRESSURE TEST

- 1) Remove the sealing bolt from the backplate - KEEP THIS SAFE AS IT WILL BE RE-FITTED LATER.
- 2) Fit the test valve to the backplate, and tighten down to provide a good seal.

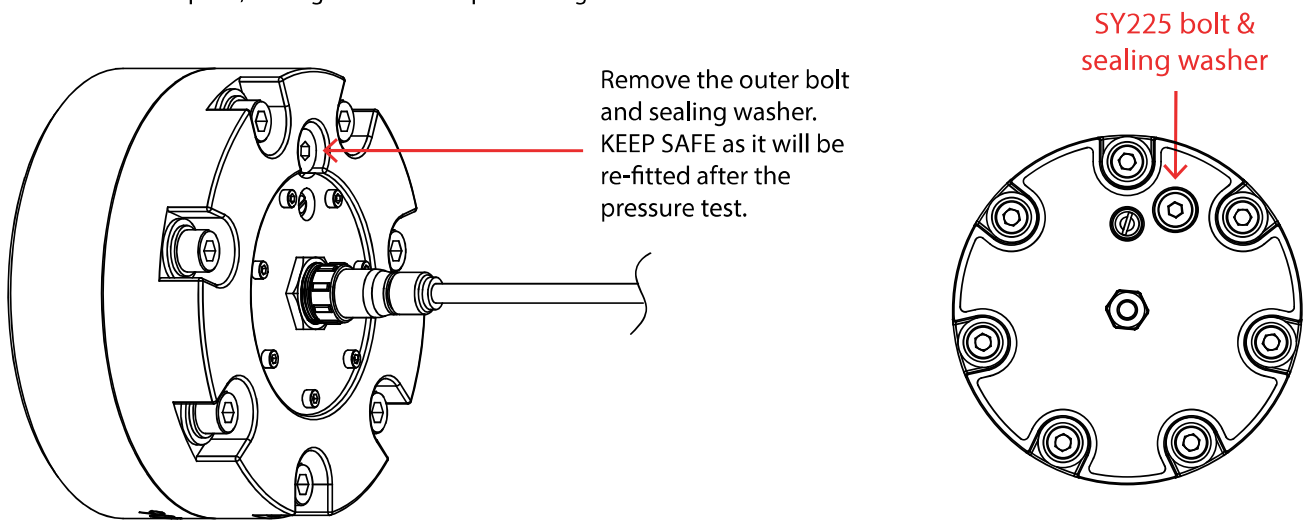

NOTE: The pressure test can be carried out with or without the cable fitted.

- 3) Fit the tube from the pressure test pump to the test valve. Using the test pump provided, pressurise the flange until it reaches a pressure of 30 PSI.

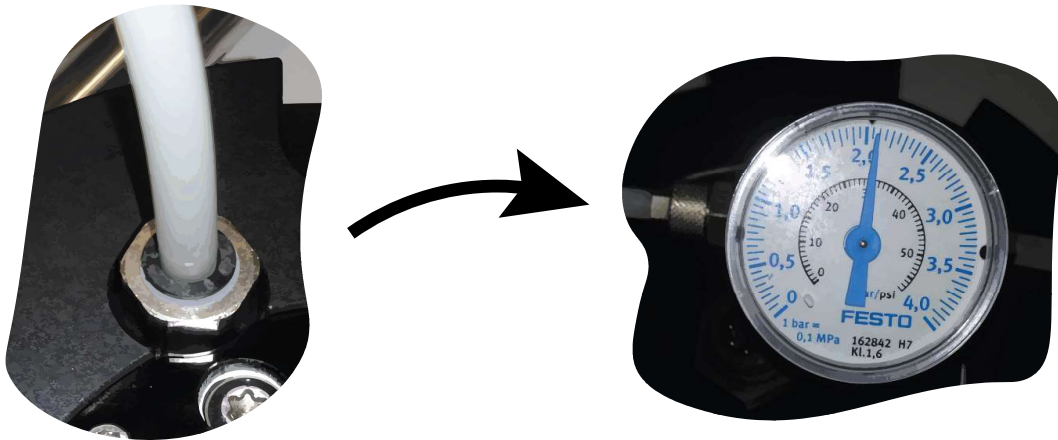

- 5) Close the valve, and monitor the pressure for 30 seconds. Check that there is NO DROP IN PRESSURE.

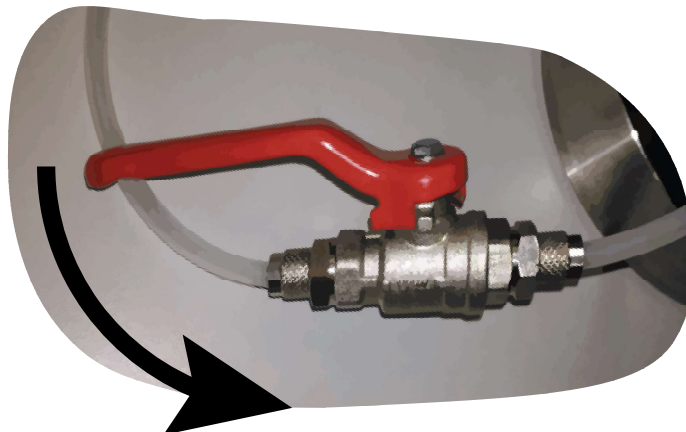

Spray Leak Detector
Spray around the edge
of the glass lens at the
front of the light

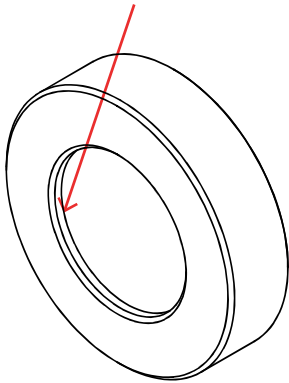

Spray Leak Detector Spray around
the interface between the light
and the flange. Look for bubbles
formed in the area spray which
will highlight any leaks

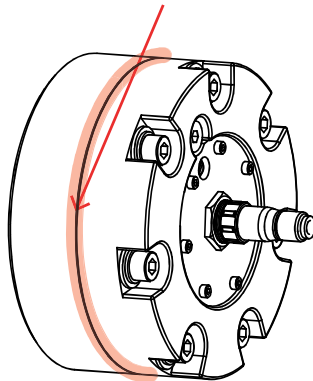

For the SY225 it is recommended
to spray around the flange and
heat base plate

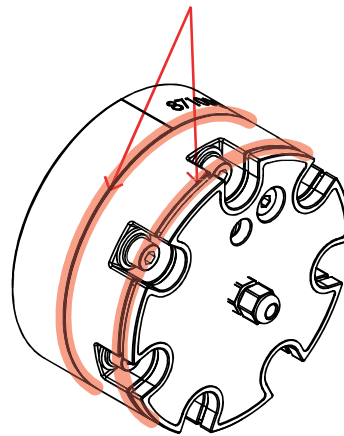

Leak Detector Spray

6) Whilst the fitting is pressurised, using a leak detector spray, spray the seal between the light and the flange, and also spray around the front lens.

7) IF the pressure cannot be maintained then the seal is not adequate. DO NOT LAUNCH THE VESSEL until this issue has been resolved, and the light can maintain pressure.

8) Once the test is complete, release the pressure. Remove the test valve, and replace the sealing bolt.

Replace the sealing
bolt and sealing washer

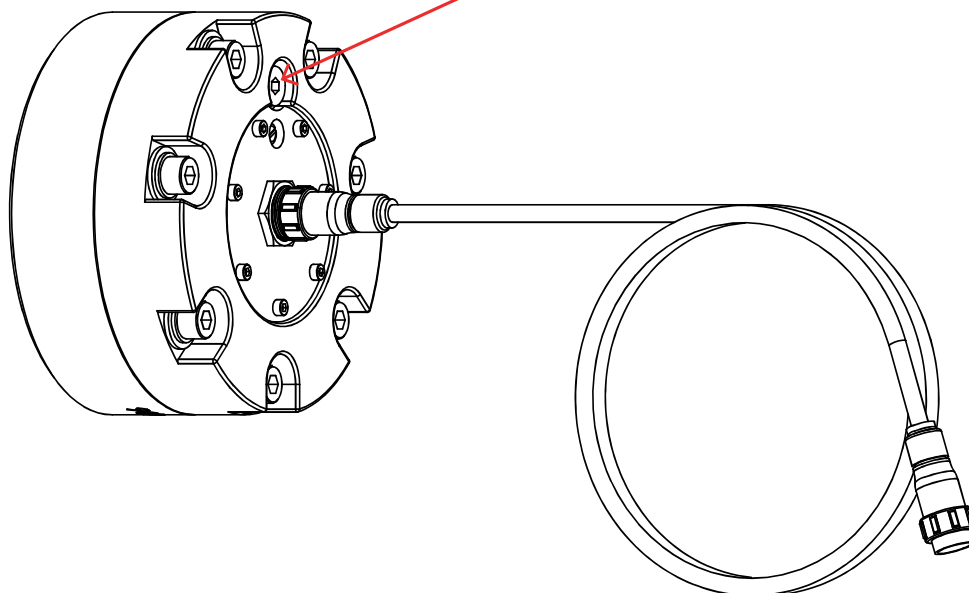

For set up and commissioning of lights refer the Light / Driver Operation Instructions